



SMP 58 Rev. A 08/18



MOBILE PRINTER
MODEL : SMP 58
Wi-Fi & Bluetooth

All specifications are subject to change without notice

**This device complies with part 15 of the FCC Rules.
Operation is subject to the following two conditions.**

- 1) This device may not cause harmful interference, and
- 2) This device must accept any interference received, including interference that may cause undesired operation.

Aures USA

Jeff Burroughs
15042 Parkway Loop, Building D, Tustin, CA 92780 | USA
+714.669.3111



**Risk of explosion if battery is replaced by an incorrectly type.
Dispose of used battery according to the local disposal instructions.**



Disposal of Old Electrical&Electronic Equipment(Applicable in the European Union and other European countries with separate collection systems)

This symbol on the product or on its packaging indicates that this product shall not be treated as household waste.

Instead it shall be handed over to the applicable collection point for the recycling of electrical and electronics equipment. For more detailed information about recycling of this product, please contact your local city office, your household waste disposal service or the shop where you purchased the product.

Table of Contents

1. Safety Precautions	4
2. Unpacking	6
3. Product Overview	7
4. Usage and Installation	8
4-1. Control Panel Usage	8
4-2. Battery Installation	9
4-3. Battery Removal	10
4-4. Battery Charging	11
4-4-1. Charging Usage	11
4-4-2. Charging Cradle	12
4-5. Set Cradle Usage	13
4-6. Belt Strap+Bracket Usage	14
4-7. Paper Installation	16
4-8. Self Test	17
5. Peripheral Connection	19
5-1. Bluetooth Connection (Optional)	19
5-1-1. NFC Connection (Optional)	20
5-2. Wi-Fi Connection (Optional)	21
5-3. Interface Cable Connection	22

6. Roll Media Specification	23
7. Black Mark	24
8. Cleaning the Printer	25
9. Printer Specification	26

1. Safety Precautions

For better safety and reliability, adhere to the following precautionary measures. Read and follow the instructions carefully before operation of the product.

Indication



Prohibition



Must follow



Do not disassemble



Unplug the power from the outlet



Grounding to prevent electric shock



Do not handle the product with wet hands



WARNING

Failure to follow these instructions could result in fire, electric shock, other injuries, or property damage.

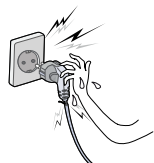

Do not pull or touch the power plug with wet hands.

(Potential risk of electric shock or fire)

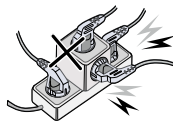

Do not overload an electrical outlet. (Potential risk of electric shock or fire)



Do not bend the wire and do not allow the wire to be pinched or crushed by heavy objects.

(Potential risk of electric shock or fire)

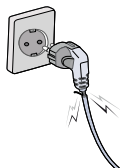

If a power plug is broken or a plug is cut or worn, do not use it.

(Potential risk of electric shock or fire)



WARNING

Failure to follow these instructions could result in fire, electric shock, other injuries, or property damage.

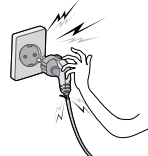

Do not unplug the power cable to turn off the product.

(Turn off the power using the power button)



Do not disassemble, repair or modify the product.

(Potential risk of malfunction, electric shock, or fire. When the product needs to be repaired, please contact your reseller)



CAUTION

Failure to follow these instructions could result in fire, electric shock, other injuries, or property damage.



Keep product away from the water and other material.

(Potential risk of electric shock or damage)

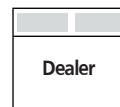

If the product needs to be repaired, please contact your reseller.

(Potential risk of fire or unit malfunction)

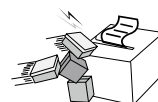

Avoid excessive shock or drops.

(Potential risk of fire or property damage)

2. Unpacking

Standard



Printer

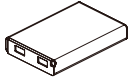

Battery

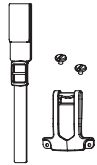

Belt Strap+Bracket

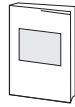

Quick Manual

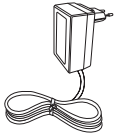

Charger

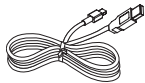

USB Cable



CD (Manual)

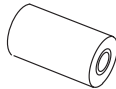

Roll paper



Set Cradle
(Charging Cradle)

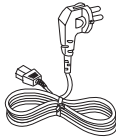

AC Cord

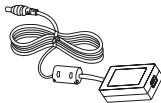

Adaptor

3. Product Overview

Front

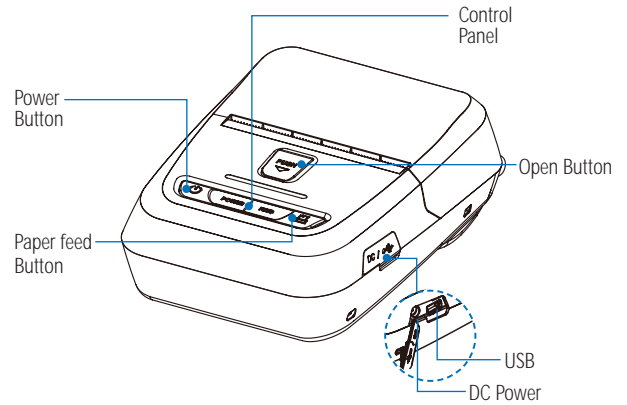

Rear

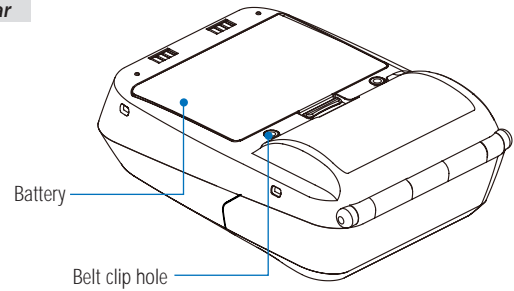

4. Usage and Installation

4-1 Control Panel Usage

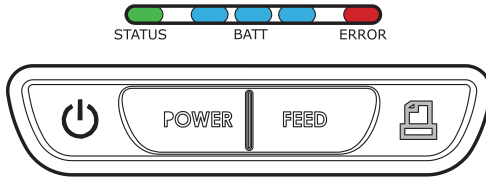

Button	Name	function
	Power Button	This button is used to turn the printer on and off. When the printer is off, press this button for approximately 3 seconds and the printer will power on. When you press this button while the printer is powered on, the printer will turn off.
	Paper Feed Button	This button can be used to manually feed the paper. Additionally, this button is also used to initiate self-tests and Hexadecimal Dumping. 1. Refer to the Self Test section of this manual for information regarding self-tests. 2. Refer to the Note in Self Test section of this manual for information regarding Hexadecimal Dumping.
	Battery Status Lamp	1. If the Batt LED is lit, the battery is fully charged. 2. If you can hear a beeping sound and LED light is turned off, the battery is at the lowest level. 3. If the battery is not charged at all, the printer turns off automatically.
	Error Lamp	If the red light is turned on, there is no paper or the paper cover is open.
	LINK/ Power Light	- LINK: LED BLINK - POWER ON: GREEN LED ON - POWER OFF: LED OFF

4-2 Battery Installation

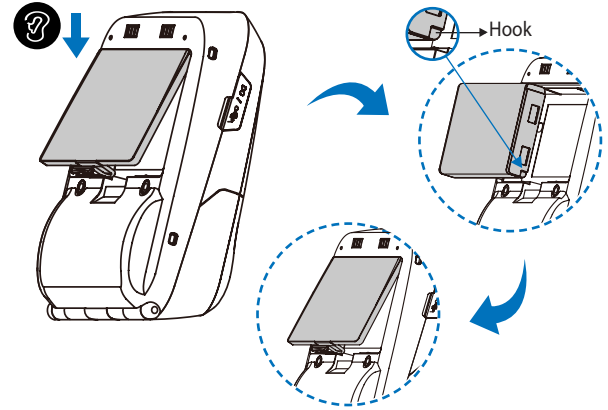

1. Align battery hook as shown in the picture
2. Push the battery into the printer until it locks in place.

NOTE

As the battery is not charged at the time of your purchase, charge the battery prior to using the printer
(Battery charger or Cradle can be used to charge)

CAUTION

Risk of explosion if the battery is replaced by an incorrect type.
Dispose of used batteries according to local regulations.

4-3 Battery Removal

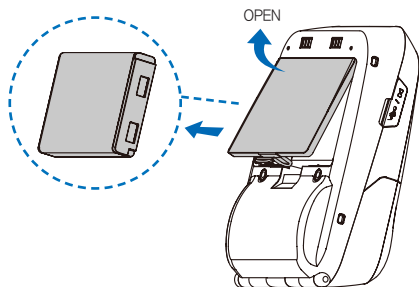

Remove the battery as shown

4-4 Battery Charging

4-4-1 Charging Usage

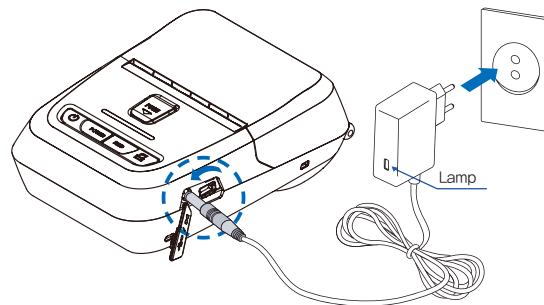

1. Make sure the printer is turned off.
2. After opening the DC JACK cover, connect the DC JACK to the printer.
3. Plug the power cord into the electrical outlet.

The charging status LED

Status	charging	charging complete
Charging Lamp	Red	Green

NOTE

1. If the charger provided by the manufacturer is not used, the printer can be damaged, and the manufacturer is not liable for the consequential damage.
2. Before removing the battery, make sure that power is turned off.
3. The printer does not work when only connected to the charger.
4. The battery needs to be installed to operate the printer.
5. While charging, do not turn on the power.
6. Do not operate the printer while charging the battery.
7. Do not connect the charger while the printer is operating.

4-4-2 Charging Cradle

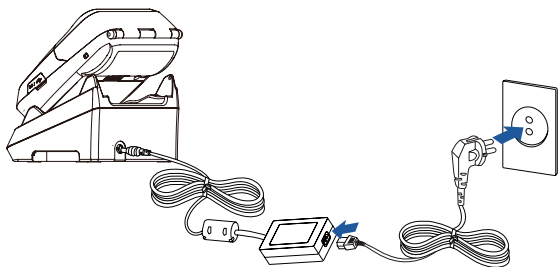

1. Place the printer into the charging cradle as shown above.
2. Connect the DC JACK to the charging cradle.
3. Plug the power cord into an electrical outlet.
4. Once the charging is completed, remove the printer from the charging cradle.

The charging status LED

Status	charging	charging complete
Charging Lamp	Red	Green

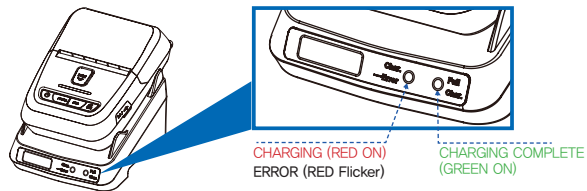

NOTE

If the printer is not properly mounted on the charging cradle, the red lamp will blink. Remove and reinsert the battery.

4-5 Set Cradle Usage

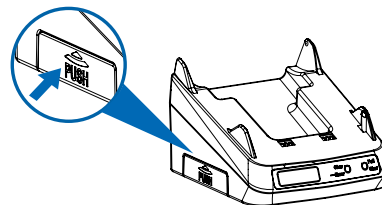

Press the PUSH button to pop out the cradle connector.

NOTE

1 Power supply can be charge up to 4 cradles in a set

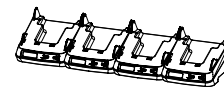

1
2

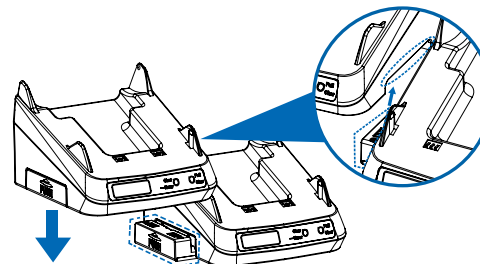

Align the second cradle with the connector of the existing cradle, and connect the cradles by pressing down.
(To disassemble, repeat these steps in reverse order)

4-6 Belt Strap+Bracket Usage

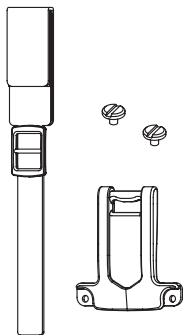

Prepare the belt strap, bracket, and 2 screws.

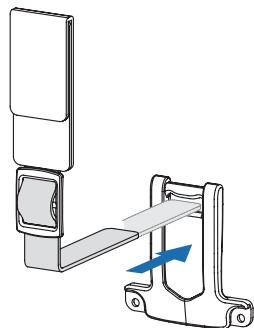

Put the strap into the hole on the top of the belt bracket.

1 2
3 4



Slide the strap into the loop on the back side.

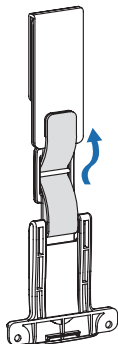

Make sure the strap is fastened tight enough.

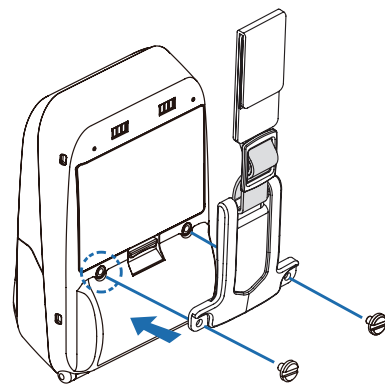

After connecting the strap and bracket, insert the screws into the bracket hole.

5
6

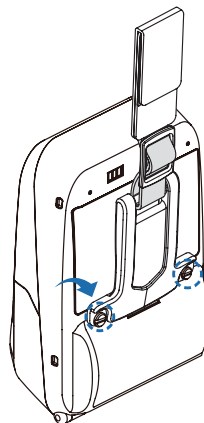

Use a screw driver to tighten the bracket.

4-7 Paper Installation

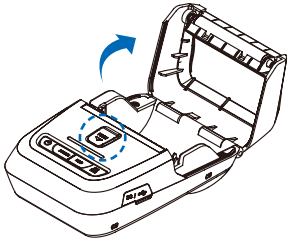

Press the PUSH button to open the paper cover.

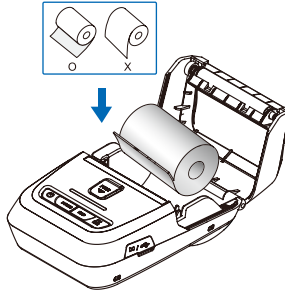

Insert the paper in the correct direction. See the image above.

1 2
3 4

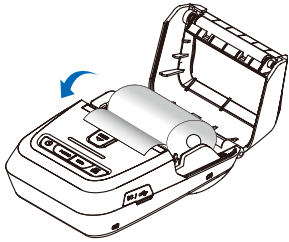

Pull a short length of paper out of the printer and close the cover.

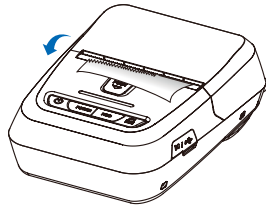

Tear off the additional paper using tear bar.

4-8 Self Test

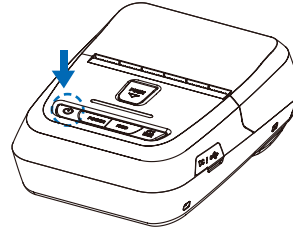

Turn off the power by pressing the power button for approximately 3 seconds.

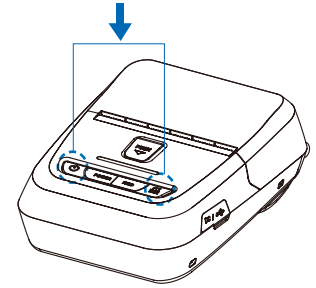

While you are holding the FEED button, press the power button.

1 2
3

✓ NOTE

1. To enter hex dump mode, press the Feed button once more
2. If the Feed button is not pressed, the self-test will automatically finish after 3 seconds.

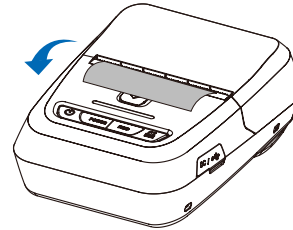

The self-test will print.

Self-Test Printout Sample



SEWOO, LK-P22

Printer Configuration Info.

F/W Version : v1.03
FontROM Version : v1.0
Black Mark(Adj) : 154(868)
Battery : 8.1V(831),offset:17
Timeout(Sleep) : 60 sec
Ext' Flash : Exist
H/W Version : v1.0
SDRAM : 6MB

Emulation Configuration Info.

Emulation : CPCL
Top Of Form : 0
Top Margin : 0
Left margin : 0

Serial Interface

Baud : 115200
Data bit : 8bit
Parity Bit : none
Stop bit : 1bit

USB Interface

Version 2.0 Full speed
compliant
Product String : LK-P22

Bluetooth Interface

Version : v0.5.39
Device Name : Mobile Printer
Mode : SPP_ONLY
Pairing Info : REGACY_MODE
Class Type : PRINTER_CLASS
Auto connection : Disabled
Address : 74:F0:7D:B0:15:05



74F07DB01505

Upon initial installation or for troubleshooting, you can run the diagnostic test to get information about:

Firmware version, emulation, codepage, sensor settings, interface settings, etc.

If no issues are found with the diagnostic test, examine other devices and software.

The diagnostic test is working independently of devices and software.

● Motor protection from being overheated

To prevent the motor from overheating, stop the printer for at least 30 seconds after continuously printing 1.5 meters.

5. Peripheral Connection

This product can communicate with other devices via Bluetooth, Wi-Fi, or a communication cable.

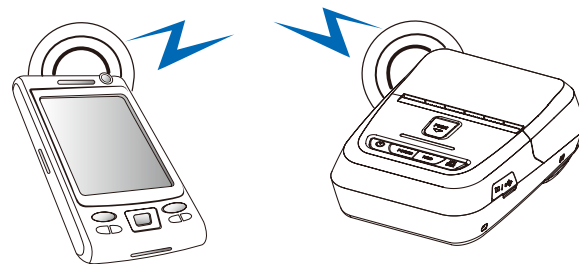

5-1. Bluetooth Connection *Optional*

1. The Printer can be connected to devices equipped with Bluetooth communication capabilities (PDAs, PCs, etc.).
2. Use the Bluetooth connection function supported by the device to connect to the printer.

☑ NOTE

- This model supports numeric comparison function.
- Please refer to the configuration manual for details.

5-1-1. NFC Connection **Optional**

This product can communicate with other devices via NFC.

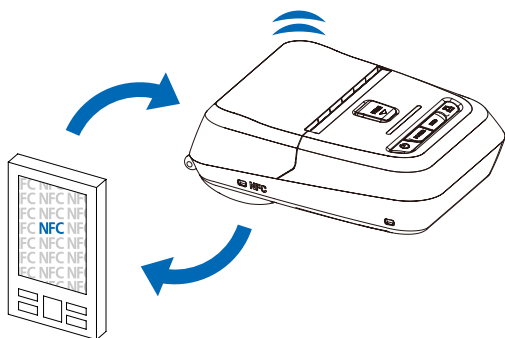

1. The printer can be connected to devices equipped with NFC communication capabilities.
2. Use the NFC connection function supported by the device to connect to the printer.

NOTE

- Please refer to the configuration manual for detail.
- NFC is only compatible with Bluetooth.

5-2. Wi-Fi Connection **Optional**

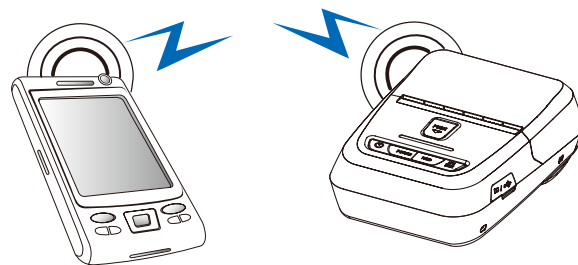

1. The Printer can be connected to devices equipped with Wi-Fi communication capabilities (PDAs, PCs, etc.).
2. Use the Wi-Fi connection function supported by the device to connect to the printer.

NOTE

- Please refer to the configuration manual for details.

5-3. Interface Cable Connection

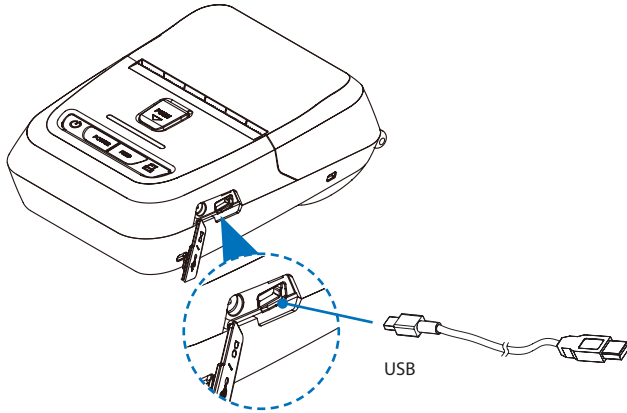

1. Connect USB cable to the connector on the printer.

NOTE

Use the cable offered by the manufacturer (USB)

2. Connect the interface cable to the USB port of the device (PDA, PC, etc.).

6. Roll Media Specification

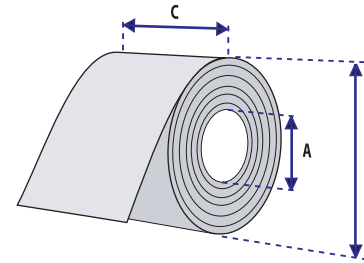

Core	
Diameter(A)	12.5mm +/-0.5mm
Roll	
Max.diameter(B)	40mm
Max.Media Width (C)	58 ± 0.5mm
Min.media Thickness	0.06mm



Protect the printhead from sand, grit, and other hard particles during printing and storage. Keep the cover closed.
Even very small foreign particles may cause severe harm to the printhead.

7. Black Mark

PAPER FEEDING DIRECTION

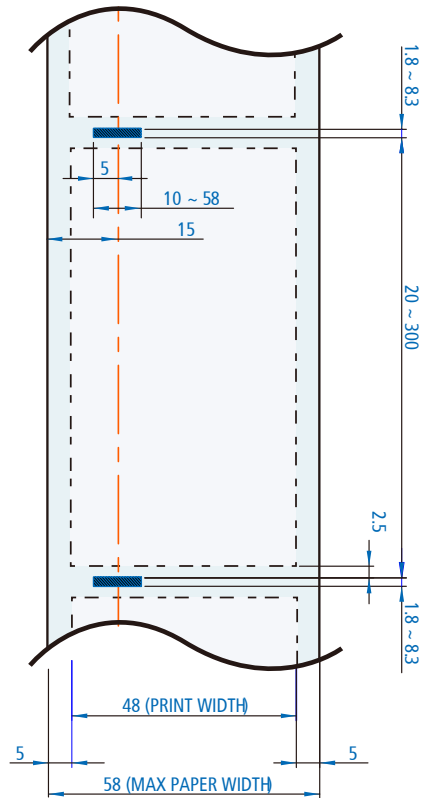

8. Cleaning the Printer

If the interior of the printer is dusty, printing quality can be lowered. In such a case, follow the instructions below to clean up the printer.

✔ NOTE

1. Make sure to turn the printer power off prior to cleaning.
2. Regarding printhead cleaning, as the printhead gets very hot during printing, turn off the printer power and wait approximately 10 minutes before cleaning.
3. When cleaning the printhead, take care not to touch the heated portion of the printhead. The printhead can be damaged by static electricity.
4. Take care not to allow the printhead to become scratched and / or damaged in any way.

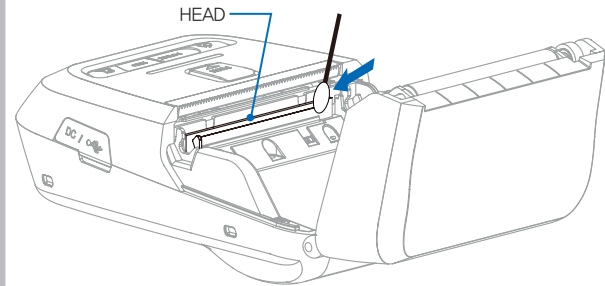

1. Use an applicator swab moistened with an alcohol solution to clean the printhead and remove any dust.
2. Once the cleaning is completed, wait a few minutes before inserting the paper roll into the printer.

✔ Preventing Overheating

To prevent the motor from overheating, stop the printer for at least 30 seconds after continuously printing 1.5 meters.

9. Printer Specification

Printing Method		Direct Thermal
Printing Speed		Max. 100mm/s
Resolution		203 DPI
Character	ESC/POS	FontA(12x24), FontB(9x17), Asian Font(KOR, JPN, CHN_GB2312, CHN_BIG5)
	CPCL	Font0/1/2/4/5/6/7, 24x24 Asian Font(KOR, JPN, CHN_GB2312, CHN_BIG5), Resident TTF, Downloadable TTF
	ZPL	FontA~H, FontGS, Resident TTF(Font0), Downloadable TTF
Barcode	ESC/POS	1D: EAN-8, EAN-13, Code39, ITF, UPC-A, UPC-E, Codabar, Code93, Code128 2D: QR, PDF417
	CPCL	1D: LUPC-A(+2,+5), UPC-E(+2,+5), EAN13(+2,+5), EAN8(+2,+5), Code39 etc. (CPCL) 2D: QR, PDF417, MicroPDF417, Maxicode, Datamatrix, Aztec, TLC39, RSS14
	ZPL	1D : Code11, ITF, Code39, Planet, EAN-8, UPC-E, Code93, Code128 etc. (ZPLII) 2D: QR, PDF417, MicroPDF417, Maxicode, Datamatrix, Aztec, TLC39, RSS14
Emulation		ESC/POS, CPCL, ZPL Command compatible
Driver		Windows Driver(10, 2012, 8, 7, 2008, VISTA, 2003, XP, 32bit & 64bit), Window CE & Mobile Driver & SDK (CE 4.2~, Mobile 5.0~-), Linux Driver, Mac Driver, OPOS Driver, JavaPOS Driver, iOS SDK, Android(2.1~) SDK, Blackberry SDK, Symbian
Sensor		Paper End Sensor, Cover Open Sensor, Black Mark Sensor
Paper	Paper type	Thermal Paper
	Width	Max. 58±0.5mm
	Thickness	0.06-0.09mm
	Roll Max Diameter	40mm
	Roll Core	12.5mm ±0.5mm

Interface	Standard	USB
	Option	Bluetooth Smart Ready Ver 4.2 or Wi-Fi(802.11a/b/g/n)
Reliability	TPH	50km
Battery Charger	Input	AC100~240V, 50/60Hz
	Output	8.4V , 800~1400mA
Battery	Battery type	Li-ion
	Output	7.4V, 1510mAh
	Charging time	2 Hrs (MSR+ICR : 2.5 Hrs)
Size [W x D x H (mm)]		80 x 119.4 x 44
Weight		242.5g (With Battery)
Temperature	Operation	-10~50℃
	Storage	-20~60℃
Humidity	Operation	35 ~ 80%
	Storage	10 ~ 90%